

# ■ MAINTENANCE INFORMATION

## CONNECTING AND DISCONNECTING CHAIN

### Introduction

Chains are manufactured with connectors, either pins or rivets of various constructions depending upon the chain type, i.e., offset or straight sidebar, Roller Chain, Fabricated Steel Chain, Welded Steel Chain, Cast Chain, Combination Chain, etc. The particular connector link construction dictates the proper method and direction of connector insertion or removal from chain.

The connectors can have uniform diameters, multiple stepped diameters, locking flats, various head styles, riveted ends or various pinlocks (cotters, etc.).

A pin with either a flat on the head end, or a larger stepped diameter will not pass through the smaller cotter-side sidebar hole. Likewise, the round shank of a pin with locking flats on the cotter end will not pass through the slotted cotter-side sidebar hole.

### Field Repair

When repairing chains in the field, the repair should be confined to replacement of complete links or sections. Replacement of individual components (bushings, rollers, etc.) is generally not recommended. Therefore, this connect-disconnect discussion has been limited to removal and replacement of connectors.

**CAUTION: Rexnord does not recommend altering or rebuilding standard press-fit chains, or sub-assemblies especially the removal of press-fit components and their replacement with others. Such alterations destroys the integrity of the press-fits of the chain assembly.**

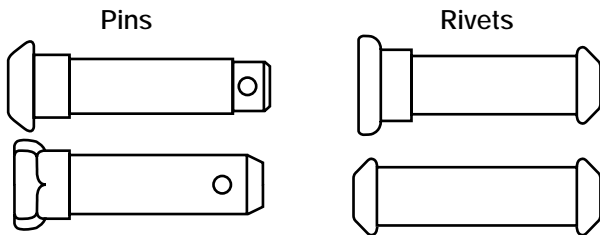

Figure 1 – Type I Connectors

### Type I Connectors

The connector construction found in the majority of chains would be of the type shown in Fig. 1.

#### Head Identification

The head of a connector can usually be identified by a alpha-numeric code stamped on it, or the appropriate sidebar is designated head side.

#### Type I Connector Removal

Type I connectors are removed by driving on the end opposite the head and supporting the link as shown in Fig. 2. Refer to pages 137-138 for disassembly tools

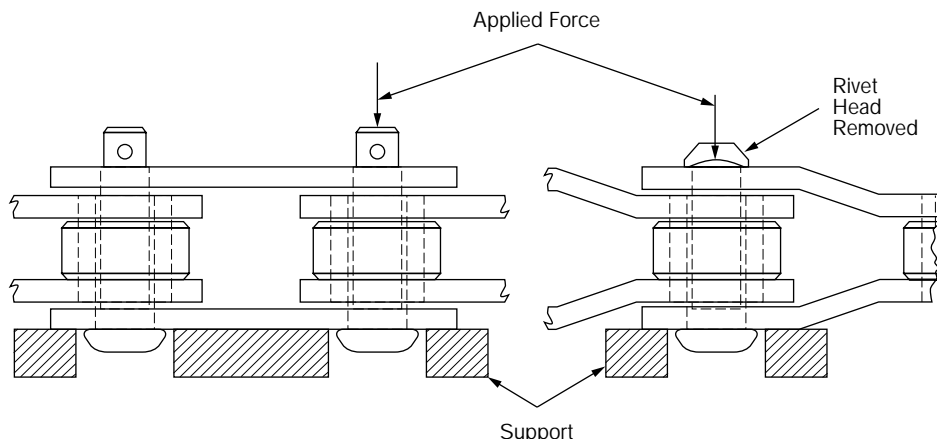

Figure 2 – Type I Connector Removal

  
**CAUTION**

**When Connecting or Disconnecting Chain**

- Always lockout equipment power switch before removing or installing chains.
- Always USE SAFETY GLASSES to protect your eyes.
- Wear protective clothing, gloves and safety shoes.
- Support the chain to prevent uncontrolled movement of chain and parts.
- Use of pressing equipment is recommended. Tools should be in good condition and properly used.

Do not attempt to connect or disconnect chain unless you know the chain construction, including the correct direction for pin/rivet removal or insertion.



For Type I single diameter rivets, the method of removal suggested for Type II connectors may be preferred. (See next page).

#### Connection

The connector is inserted by driving on the head end of the connector and supporting the link similar to the manner shown in Fig. 2.

# MAINTENANCE INFORMATION

## CONNECTING AND DISCONNECTING CHAIN – (Cont'd.)

### Connection

For connection, one sidebar is pushed onto one of the ends of the connectors and the other sidebar is pushed onto the opposite ends of the connectors. Refer to pages 137-138 for assembly tools.

### Pinlocks

For cast and roller chains, the pinlocks (cotters, etc.) should be removed before pin removal. Cast chains could be damaged from the pinlock if left in during pin removal. Roller chains normally use hardened pinlocks making cutting or shearing difficult. However, for most other chains, both ends of pinlocks should be cut flush (with chisel or equivalent) with outside diameter of pin to prevent pin collapse during pin removal.

### Riveted Ends

For chains of riveted construction, the riveted end should be ground flush with the sidebar before connector removal.

### Loose Chain

When disconnecting and connecting loose chain, the chain should always be solidly supported against the floor, or on a bench. When employing method of Fig. 2, enough space should be provided below the end (at least twice the sidebar thickness) to allow the connector end to pass through the sidebar.

## TYPE II CONNECTORS

Connectors of Type II construction shown in (Fig. 3) are typically found in hollow rivet, draw bench, double flex and S-Series Chains.

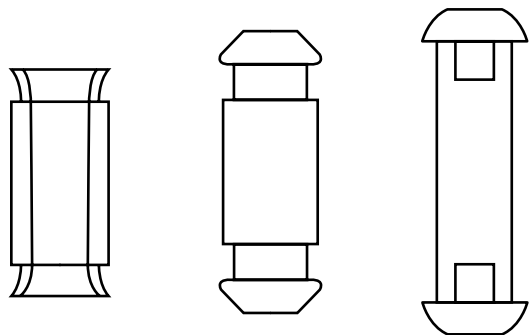

Figure 3 – Type II Connectors

### Removal

Type II connectors are moved in the method shown in Fig. 4. They are removed by supporting the top sidebar and pushing the ends of the connectors free of the sidebar. An alternate method is to wedge or pry the sidebars free of the connectors.

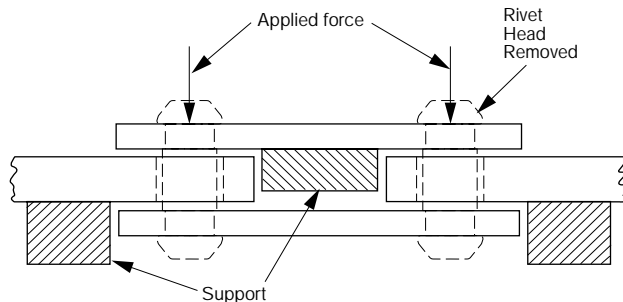

Figure 4 – Type II Connector Removal

### To Disconnect Chains on Sprockets

1. Decrease chain tension by loosening, take-ups, etc.
2. Restrain sprockets from rotating and secure chain on both sides of disassembly point.
3. Apply penetrating oil around connectors.
4. Remove where chain wraps over the sprockets. Support against removal force with heavy bar or tubing held against opposite side of the chain and sprocket.
5. Grind riveted end (if present) of connector flush with the sidebar.
6. Remove pinlocks or cut ends flush with outside diameter of pin.
7. Use press equipment to remove connectors, e.g., hydraulic press or jack, or arbor press.

### IMPORTANT! SAFETY INSTRUCTIONS

- Follow safety guidelines on preceding Caution Tag.
- Don't heat or cut chain with torch unless absolutely necessary. Any links or pins heated by such a process should be replaced during reassembly.

### To Connect Chains on Sprockets

1. When connecting strand use sprocket for rigid support. Support against assembly force with heavy bar or tubing held against opposite side of chain and sprocket.
2. Grease or oil the connector before replacing it.
3. Check connectors to assure proper positioning of flats or cotter holes before assembly.
4. Use press equipment to insert connectors, e.g., hydraulic press or jack or arbor press.
5. Check to see that assembled joint(s) flex freely. If not, a light blow exerted on opposite end of connector(s) should free joint(s).

### IMPORTANT! SAFETY INSTRUCTIONS

- Follow safety guidelines on preceding Caution Tag.
- Don't grind the circumference of the connector of the sidebar hole to ease insertion of the connector.
- Do not heat sidebars to ease pin insertion.

# ■ MAINTENANCE INFORMATION

## DRIVE CHAINS

The following suggestions are practical methods of increasing chain and sprocket life. The more of them that are followed, the longer the chain and sprocket life will be.

### Lubrication

Lubrication is essential for maximum chain and sprocket life. Drive chains can and should be lubricated.

Lubrication effectiveness will vary with the amount of lubricant used and frequency of application. Ideally, a lubricant film should constantly be maintained between working parts.

### Chain Operation

If possible, manually lubricate the chain once a week when the chain is not under load. It is important to get the lubrication between the pin and the bushing and between the roller and the bushing. The chain is under the least load after it exits from the driver sprocket. This area will contain a catenary sag and this is the area to which manual lubrication should be applied. Pour or brush on a copious amount of oil in a continuous manner. Allow the chain to travel two complete cycles.

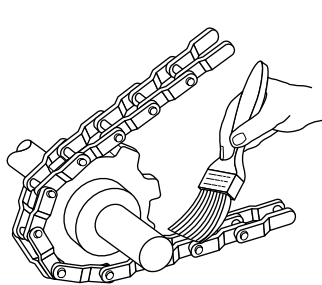

Manual Lubrication

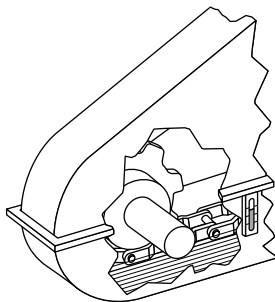

Oil Bath Lubrication

Chains operating at relatively high speeds should be completely enclosed in an oil case. The lower strand of the chain should just dip into the oil when the chain is running. Maintain the proper oil level. Excess oil causes churning and heat.

### Type of Lubricant

Oil is recommended as a lubricant using the highest viscosity that will flow at the prevailing temperature:

Temperature (°F)	Lubricant
Below 40 .....	SAE 30
40-100 .....	SAE 40
Above 100 .....	SAE 50

### Sprockets

Worn or improperly designed sprockets are one of the main causes for premature chain life or chain failure. Here are a few hints on how to get the most out of sprockets.

### New Sprockets

1. When receiving new sprockets check to see if the sprockets are in pitch by wrapping the chain around sprocket and coupling.
2. Make a "Painted Pattern" by holding a piece of wood behind the new sprocket tooth and spray paint the tooth outline onto the wood. As the sprocket wears, a check on what the original shape was and how much wear has taken place can be made by putting the painted pattern behind the tooth.

### Tooth Wear

On single direction drives only one side of the tooth wears. Reverse the sprocket on the shaft and put the unworn tooth face to work.

### Chain and Sprocket Interaction

Closely inspect the Chain and Sprocket interaction to insure a smooth and noiseless operation. The chain should easily enter and exit the sprocket without a hitch.

### Chain Elongation

Wear on the pin outside diameter and bushing inside diameter causes chain elongation. Once the chain has elongated or worn past acceptable limits, jumping of sprocket teeth and/or improper chain-sprocket interaction can be expected. Typical allowable elongations are 3 to 5% of chain pitch for drive chains. After the chain has been elongated or worn past acceptable limits, it should be replaced.

### How to Dimensionally Identify Chain:

First check chain for any markings!

1. Determine if sidebars have straight or offset construction.
2. Measure chain pitch.
3. Measure pin diameter.
4. Measure roller diameter & width.
5. Measure sidebar thickness & height.
6. Measure bushing length.

**FOR BEST RESULTS, CLEAN CHAIN AND SPROCKET PERIODICALLY.**

# MAINTENANCE INFORMATION

## CONVEYOR CHAINS

Wherever possible, lubrication of chain is always recommended to assure maximum chain life and optimum conveyor operation. The reduction in friction and increase in wear life usually justifies the additional cost.

Under normal conditions, chains with roller are selected only when proper lubrication is possible.

In some applications the presence of a lubricant cannot be tolerated, but it still may be possible to attain satisfactory service with sacrifice to chain and conveyor life.

*The following are general guides:*

### Type of Lubricant

Oil is recommended as a lubricant. Use the same lubricants recommended for drive chains at the same temperature ranges.

Grease can be used if it is applied internally into the joint with lubrication fittings on rivets or bushings.

### Method of Lubrication

Oil flow or brush type lubrication is adequate under relatively clean conditions, but they are ineffective with dirty conditions. "Flush" lubrication (flooding the chain) once per day is normally adequate in dirty environments.

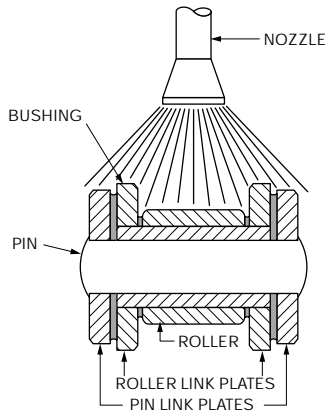

When manually lubricating, the oil should be directed between adjacent outer and inner sidebars (for the joint) and between inner sidebar and roller face (for roller-bushing lubrication). **For best results, clean chain and sprocket periodically.**

The effectiveness of any lubrication method will vary with the amount of lubricant used and the frequency of application. Ideally, a lubricant film should be maintained between working parts.

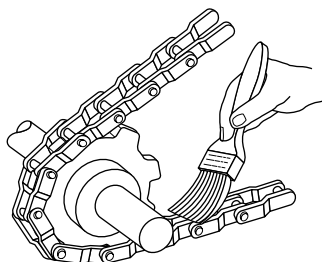

### Chain and Sprocket Storage

Do not store in an "open" area where dust, dirt and water are present. **Sprockets**, especially the tooth face and the inside of the bore, should be painted with a heavy lubricant to prevent corrosion.

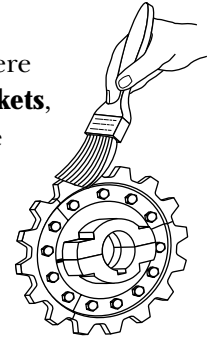

Most manufacturers pre-lubricate chain when it is shipped from the manufacturing plant. If you do not intend to use the chain when you receive it and it will be stored for a period of time, the chain should be lubricated periodically. If possible, store chain in a fifty gallon drum or other container filled with "Used Drain Oil." This will provide excellent protection for the chain as well as good break-in lubrication for the chain when it is finally used. This pre-lubrication will allow the chain and sprockets to "break in" or "shine-up" properly. If a chain is installed into the application completely dry this will reduce its overall life.

If it is impossible to store in "lubricated" environment, then oil the chain after installation but before any load is applied. Run the chain for 24 hours without any load to allow for good break-in. It is also a good idea to lubricate drag chain conveyor ways with moly-disulfide so that a proper surface will develop between the chain ways and the chain.

### Chain Installation

Do not grind the chain pins or the holes in the sidebar in order to assemble the chain. Chain reliability is based upon a good press fit of the pins into the sidebars. If you reduce that press fit you can reduce chain life. Lubricate the pin when installing it, this eases assembly.

### Chains on Idle Equipment

If the equipment is to be idle for any length of time, clean the chain and sprockets by brushing or swabbing if possible, or with a steam hose. Then cover the chain and sprockets with a light oil.

### Chain Operation

If possible, manually lubricate the chain once a week when the chain is not under load. Try to flow the oil between the pin and bushing and between the roller and the bushing. Usually the chain is under the least load after it exits from the driver sprocket. This area should contain a catenary sag, and this is the area that manual lubrication should be applied. Flow or brush on a predetermined amount of oil in the shortest amount of time possible, but still allowing the chain to travel two complete cycles.

# MAINTENANCE INFORMATION

## CHAIN ASSEMBLY/DISASSEMBLY TOOLS

### - DRIVEMASTER®

Assemble and disassemble Rex® and Link-Belt® Drive Chains quickly and safely with these portable tools. Keep the advantages of interference fit, thereby maintaining optimum chain fatigue life. The design of these tools will facilitate assembly or disassembly of catalog listed drive chains, through 7 inch pitch.

Features	Benefits
1. Easy-to-use	Reduces down-time. Eliminates cumbersome assembly/disassembly methods.
2. Maintains Press-Fits	No hammering or back-up required. Insures optimum chain fatigue life.

Drivemaster I*			
No. 3	RO635	RX1207	B3112
RX238	R778	1240	R3112
R362	1030	1244	B3113
R432	R1033	RX1245	3120
R506	R1035	R1248	3125
R514	1037	X1343	3140
A520	A1204	X1345	3160CN
B578	RO1205	AX1568	3180
R588			

Drivemaster II*			
RO1306	RX9506	X1311	X1365
ROS1306	1301	X1307	A1309

\* Contact Rexnord for non-listed chains. Rex drive chains are listed. To interchange Link-Belt and Rex chain numbers see pages 34-35.

### TO DISASSEMBLE CHAIN:

1. READ AND FOLLOW ALL PRECAUTIONS LISTED ON CHAIN TOOL.
2. Be sure to use the correct chain adapters for the chain being disassembled.
3. Remove dust cover from cylinder and connect pump hose to cylinder by finger tightening.
4. Be sure cylinder is completely collapsed. If not, open relief valve (counterclockwise) and push ram in.
5. Close relief valve on hand pump (clockwise).
6. Remove cotters or pinlocks. If this is not possible, tool will shear off without damage to chain or tool, but repinning may be difficult due to the sheared cotter or pinlock that is pressed in the hole. Cover cotter with rag before shearing.
7. Place chain link to be disassembled securely in saddle with cotter end of pin facing toward ram.
8. For stability it may be helpful to secure pump to steel plate or flat board.
9. Apply pressure by pumping hand pump. Be sure ram is squarely on end of pin and that head end will clear discharge slot on opposite end.
10. After pin is free of sidebars remove pin from chain link by pulling through discharge slot.
11. To remove chain from unit, open relief valve – (counterclockwise) and close cylinder by pushing ram in.
12. Replace dust cover on cylinder.

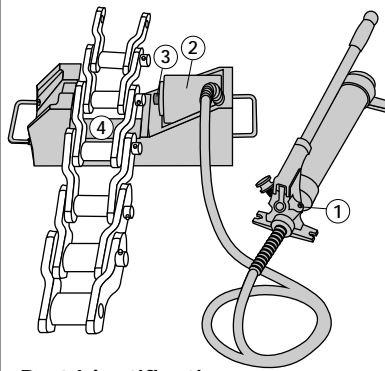

#### Part Identification

- ① Relief Valve
- ② Cylinder
- ③ Ram
- ④ Saddle and Support Plate

### TO ASSEMBLE CHAIN:

1. READ AND FOLLOW ALL PRECAUTIONS LISTED ON CHAIN TOOL.
2. Be sure to use the correct chain adapters for the chain being assembled. Adapters are labeled with chain number.
3. Remove dust cover from cylinder and connect pump hose to cylinder by finger tightening.
4. Place pin in chain joint to be assembled by hand as far as possible. Line up pin locking flats where applicable; tap pin with hammer to “Snug-Up”, (improper alignment could shear hole).
5. Close relief valve on hand pump (clockwise).
6. Place chain joint securely in saddle (4) with pin head facing toward ram.
7. For stability – it may be helpful to secure pump to steel plate or flat board.
8. Apply pressure by pumping hand pump. Be sure that ram is squarely on pin head.
9. After pin head is flush with sidebars open relief valve – (counterclockwise) and close cylinder by pushing ram down. Remove chain.
10. If chain does not flex freely, hit pin cotter end hard with hammer to establish clearance.
11. Replace dust cover on cylinder.

### PRECAUTIONS

1. Always wear safety glasses.
2. Take necessary precautions to secure chain.
3. Be sure to use correct chain adapters.
4. This tool is not to be used to manufacture chain.
5. Do not hammer on this unit when it is under pressure, or at any other time!
6. Always use the hand pump supplied with this unit. Drivemaster will not be supplied without hand pump.
7. When not in use, be sure dust covers are replaced.
8. Use this tool only with the chains recommended by Rexnord Corp.

# MAINTENANCE INFORMATION

## CHAIN ASSEMBLY/DISASSEMBLY TOOLS - LINKMASTER®

Keep the advantages of interference fit by eliminating pin grinding or heating of sidebars which decreases the fatigue strength of the chain, resulting in premature chain failure.

The design of this tool will facilitate assembly or disassembly of larger straight sidebar chains including the Rex® ER800 and ER900 Series and Link-Belt® SBX800 and SBX2800 Series elevator chains. The outstanding “mobility” of this tool allows usage “in the elevator” as well as on the floor.

Contact Rexnord for chains not mentioned above.

### Elevator Chains - Rex ER800 and ER900 Series - Link-Belt SBX800 and SBX2800 Series

For detailed dimensions of these chains, see “Numerical Chain and Sprocket” index for page location.

#### ASSEMBLY

1. Insert pin in joint as far as possible. A light coat of oil may be applied to the pin O.D. and sidebar holes to facilitate assembly. Tap the pin lightly with a hammer to provide a snug fit as improper alignment could damage the holes.
2. Place the Linkmaster over the chain joint, and apply pressure squarely on the pin head. Make sure the cotter end clears the recessed contact plate on the opposite end (see View “A”).
3. Apply pressure until the pin head is almost flush with the sidebar. Check the Linkmaster periodically so it doesn't slip off of the pin.
4. Open the relief valve to reduce pressure.
5. Insert the cotter.
6. Apply a firm hammer blow on the end of the pin to loosen the joint so it may flex freely.
7. Insert spacer gage between the inside surfaces of the outside sidebars to verify the proper width between them has been maintained.
8. Replace the dust cover on the cylinder.

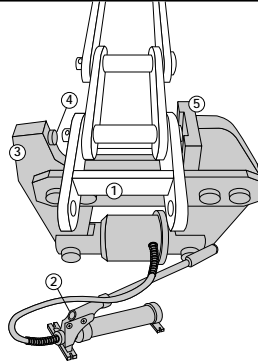

#### Part Identification

- |                                      |                 |
|--------------------------------------|-----------------|
| ① Spacer Gage (Rectangular Flat Bar) | ③ Force Arm     |
| ② Relief Valve                       | ④ Ram           |
|                                      | ⑤ Support Plate |

#### DISASSEMBLY

Tool shown in chain disassembly position. To reassemble chain, reverse tool so ram (4) contacts pin head.

1. Be sure cylinder is completely collapsed.
2. Close relief valve on hand pump.
3. Remove cotters, if possible. Otherwise, the Linkmaster will shear them off without damage to the chain or itself.
4. Apply pressure by pumping hand pump. Be sure ram is squarely on end of pin and that the head end clears the recessed contact plate on the opposite end (see View “B”). Check this periodically until pin is free of sidebars. Failing to do this could damage pump.
5. To remove unit from chain, open relief valve and close cylinder by pushing force arms together. Newer models have automatic spring return cylinders.
6. Replace the dust cover on the cylinder.

#### VIEW A

Rex Linkmaster tool shown positioned to assemble ER864 chain. Apply pressure to pin head only until it contacts sidebar. Be sure pin end will clear support plates shown in View “A”.

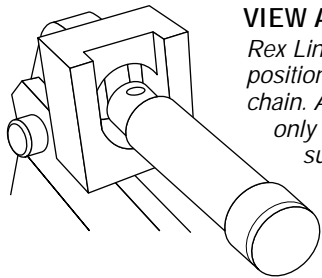

#### VIEW B

Tool shown positioned to disassemble ER864 chain. Be sure pin head will clear support plate as shown in View “B”.

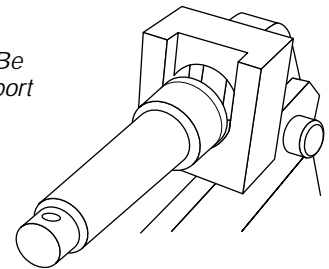

#### PRECAUTIONS

1. Always wear safety glasses.
2. Take necessary precautions to secure chain.
3. Be sure to use correct chain adapters.
4. This tool is not to be used to manufacture chain.
5. Do not hammer on this unit when it is under pressure, or at any other time!
6. Always use the hand pump supplied with this unit. Drivemaster will not be supplied without hand pump.
7. When not in use, be sure dust covers are replaced.
8. Use this tool only with the chains recommended by Rexnord Corp.